



# **RocketStor 8531AW (RS8531AW)**

## **Gen4 External PCIe Chassis User Guide**



**V1.00 - March 20, 2025**

Copyright 2025 HighPoint Technologies, Inc.

All rights reserved

# Table of Contents

<b>1. Overview .....</b>	<b>2</b>
<b>1.1. Key Features .....</b>	<b>2</b>
1.1.1. FRU .....	3
1.1.2. Hardware Secure Boot .....	3
<b>2. RS8531AW Hardware Description .....</b>	<b>4</b>
<b>2.1. RS8531AW Layout .....</b>	<b>4</b>
2.1.1. Host Interface Card--Front View .....	4
2.1.2. Host Interface Card--Diagnostic LED View .....	6
2.1.3. External Chassis Device--Front View .....	7
2.1.4. External Chassis Device--Rear View .....	8
2.1.5. External Chassis Device--Internal View .....	10
<b>2.2. PCIe Host Interface .....</b>	<b>11</b>
<b>2.3. Chassis Bus Interface .....</b>	<b>11</b>
<b>2.4. Basic Specifications .....</b>	<b>11</b>
<b>3. Controller Card Connector .....</b>	<b>12</b>
<b>3.1. CDFP Connector Pin Designation .....</b>	<b>12</b>
<b>3.2. CDFP Connector Pinout .....</b>	<b>15</b>
<b>4. Cable Accessory .....</b>	<b>18</b>
<b>4.1. CDFP-CDFP-1M .....</b>	<b>18</b>
4.1.1. Cable Diagram .....	18
4.1.2. Cable Drawings and Pinouts .....	18
<b>5. RS8531AW Installation Instructions .....</b>	<b>20</b>
<b>6. Revision History .....</b>	<b>23</b>
Version 1.00, March 20, 2025 .....	23

# 1. Overview

The RS8531AW is the latest member of our PCIe Gen4 External PCIe Chassis product family.

Designed specifically for GPUs, this PCIe 4.0 chassis stands out as the ultimate solution for high-performance computing and data center applications. Leveraging the latest PCIe 5.0 interface standard, it dramatically enhances data transfer speeds, offering unparalleled high-speed connectivity for premium graphics processors. With optimized cooling design and expandability, it ensures system stability even under prolonged high-load operations.

## 1.1. Key Features

- Dedicated PCIe 4.0 x16 host interface
- Provide one internal PCIe x16 slot
- Provide one CDFP Gen5 Version Host Port Type
- Support data transfer rate 32GB/s
- Support one GPU
- Support all GPU Dimension (Up to 370mm \* 170mm \* 88mm)
- Complies with CoopLink Copmliant standard
- FRU Inventory support
- Software Secure Boot
- Hardware Secure Boot
- Real-Time Power Measurement
- Asterolabs PCIe 4.0 Retimer Technology
- Support LED Management
- Support Fan Control
- Support Alarming
- All the Operating Systems that support the PCIe standard

### 1.1.1. FRU

The *Field Replacement Unit (FRU)* ensures smooth operation and efficient maintenance of complex systems. The unit is designed to house and protect vital product data (VPD).

Information fields within a VPD resource type contain a three-byte header and some data. The three-byte header contains a two-byte keyword and a one-byte length. A keyword is a two-character (ASCII) mnemonic that uniquely identifies the information in the field. The last byte of the header is binary and represents the length value (in bytes) of the following data.

In the event of a hardware failure, the *FRU* can be quickly replaced, returning the device to a fully functional state without requiring extensive diagnostics or data recovery. This reduces downtime and minimizes the possibility of data loss, ensuring that critical operations can continue uninterrupted.

The following table describes the details and descriptions of the VPD.

**Table 1: Details and Descriptions of the VPD**

Key Word	Details	Descriptions
PN	AIC Part Number	This keyword is an extension to the Device ID (or Subsystem ID) in the Configuration Space header.
EC	Engineering Change Level	The characters are alphanumeric and represent the engineering change level for this add-in card.
MN	Manufacture ID	This keyword is an extension of the Vendor ID (or Subsystem Vendor ID) in the Configuration Space header. It allows vendors to identify an additional level of detail regarding the sourcing of this device.
SN	Serial Number	The characters are alphanumeric and represent the unique add-in card Serial Number.
Vx	Vendor Specific	This is a vendor-specific item, and the characters are alphanumeric. The keyword's second character (x) can be 0 through 9 or A through Z.  V0 indicates the Vendor Name  V1 indicates the Main Chip

### 1.1.2. Hardware Secure Boot

The secure boot feature permits only authenticated firmware to execute. The switch boots the root of the trusted firmware from the internal boot ROM (IBR) and uses that firmware to authenticate the external firmware stored in the SPI flash and prevent the execution of unauthenticated code.

## 2. RS8531AW Hardware Description

### 2.1. RS8531AW Layout

The layout of the RS8531AW is presented in five parts.

#### 2.1.1. Host Interface Card--Front View

The following figure shows the key components of the host interface card.

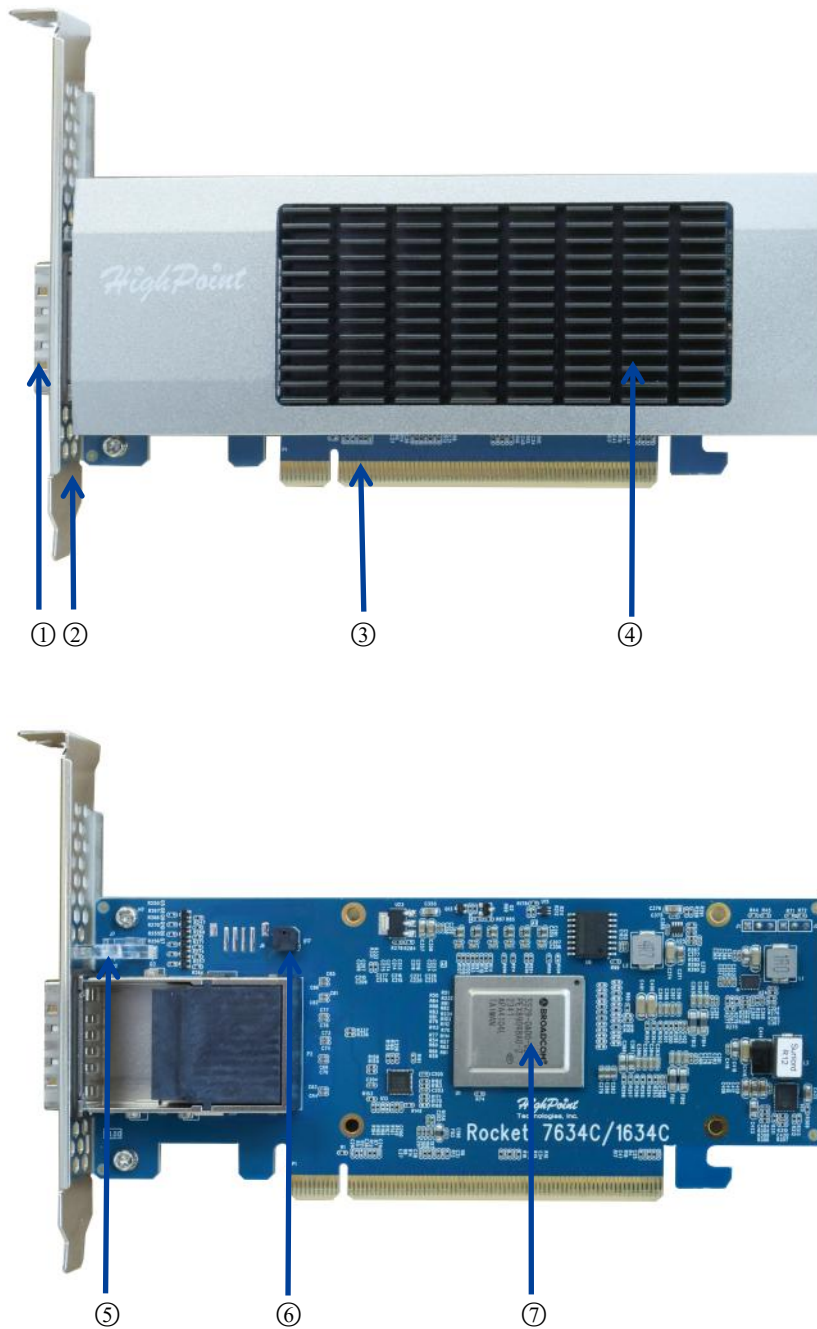

The following table describes the key components of the host interface card.

盘箱MCU反馈的速率

**Table 2: Key component of the host interface card**







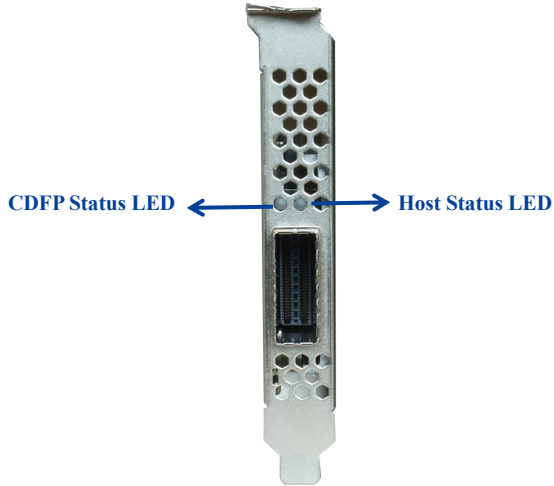



Number	Type	Description
①	CDFP Connector	One CDFP connector. Connect the controller card using a CDFP cable to the Chassis.
②	Bracket	Full-height bracket. (optional low-profile bracket included). The RS8531AW is secured to the chassis by a bracket.
③	PCIe Host Interface	PCIe 4.0 x16 host interface. The interface between the host interface card and the host system. With the PCIe interface, this connector provides power to the board.
④	Cooling System	Passive Heatsink. Used to dissipate heat from electronic components prone to heat generation.
⑤	Diagnostic LED	CDFP Status LED and Host Status LED. <ul style="list-style-type: none"> <li>● CDFP Status LED -- The bandwidth of the Chassis MCU feedback.</li> <li>● Host Status LED -- The status of the host interface card PCIe bandwidth.</li> </ul>
⑥	Beeper	This beeper is for factory commissioning only.
⑦	Chip	Broadcom PEX 89048 chip.

## 2.1.2. Host Interface Card--Diagnostic LED View

The following figure shows the LED Indicators of the host interface card.

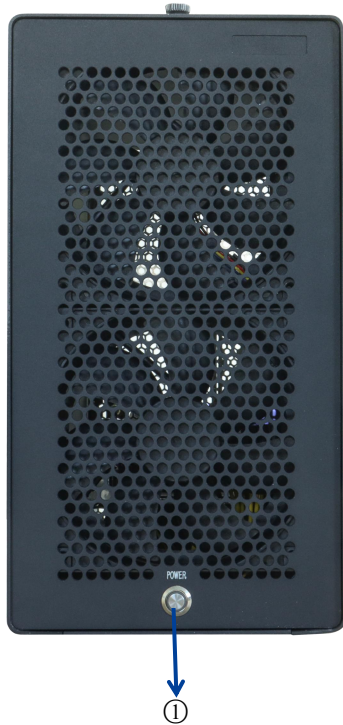

**Table 3: LED Indicators of the host interface card**

LED	Color	Status	Description
CDFP Status LED		OFF	The Chassis is powered off.
		Solid Blue	The CDFP status is working at PCIe 4.0 with 1 x16 Mode.
		Flash Blue	The LED blinks red at 4 Hz to indicate that the CDFP status is working at not PCIe 4.0 but 1 x16 Mode.
Host Status LED		OFF	The host interface card is powered off.
		Solid Blue	The host interface card's bandwidth is PCIe 5.0 x16.
		Solid Green	The host interface card's bandwidth is PCIe 5.0 x8 or PCIe 4.0 x16.
		Solid Yellow	The host interface card's bandwidth is PCIe 4.0 x8 or PCIe 3.0 x16.
		Solid Cyan	The host interface card's bandwidth is PCIe 4.0 x4 or PCIe 3.0 x8.
		Solid White	The host interface card's bandwidth is PCIe 3.0 x4.
		Solid Red	The host interface card's bandwidth does not appear as above.

### 2.1.3. External Chassis Device--Front View

The following figure shows the key components of the Chassis front panel.



The following table describes the key components of the Chassis front panel.

**Table 4: Key components of the Chassis front panel**

Number	Type	Description
①	Power Switch	<p>ON/OFF Switch.</p> <p>The power switch of the Chassis can be controlled by pressing the power switch.</p> <p>Note: In the “On” state, the switch illuminates with a blue light; in the “Off” state, it remains unlit.</p>



## 2.1.4. External Chassis Device--Rear View

The following figure shows the key components of the Chassis rear panel.

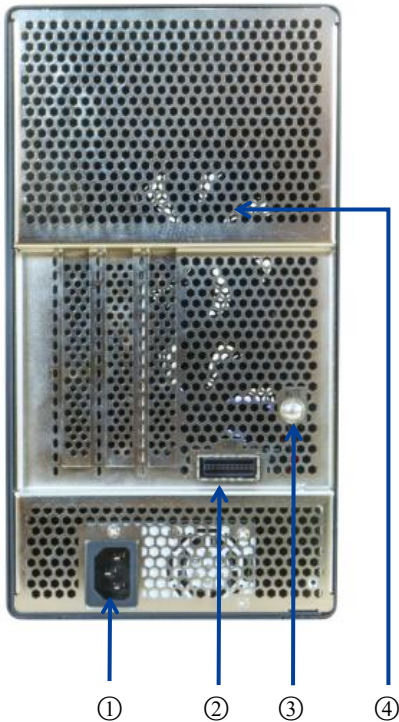

The following table describes the key components of the Chassis rear panel.

**Table 5: Key components of the Chassis rear panel**

Number	Type	Description
①	AC Power IN	Used to connect the AC power cord.
②	CDFP Connector	Upstream Port for the Chassis. Used to connect the host interface card via CDFP cable.
③	Mute Button	Used to mute the beeper of the Chassis.
④	Fan	Built-in Low-Decibel fans. Used to dissipate heat from disks that are prone to heat generation.
		Smart Fan Control
		<p><b>Lower Speed:</b></p> <p>Situation 1: The LM75 temperature is &lt; 30°C.</p> <p>Situation 2: The Retimer chip temperature is &lt; 65°C.</p>
		<p><b>Linear Speed:</b></p> <p>Situation 1: The LM75 temperature is between 30°C and 50°C.</p> <p>Situation 2: The Retimer chip temperature is between 65°C and 75°C.</p>
		<p><b>Full Speed:</b></p> <p>Situation 1: The LM75 temperature is &gt; 60°C.</p> <p>Situation 2: The Broadcom chipset temperature is &gt; 75°C.</p>

		<b>Note: The fan speed choice depends on the higher temperature.</b>	
		<b>Manual Fan Control</b>	<b>0:</b> Ultra Low Speed (Around 480 RPM, $\pm 20\%$ )
			<b>1:</b> Low Speed (Around 960 RPM, $\pm 20\%$ )
			<b>2:</b> Medium Speed (Around 1200 RPM, $\pm 20\%$ )
			<b>3:</b> High Speed (Around 1380 RPM, $\pm 20\%$ )
			<b>4:</b> Full Speed (Around 1560 RPM, $\pm 20\%$ )

## 2.1.5. External Chassis Device--Internal View

The following figure shows the key components of the Chassis internal panel.

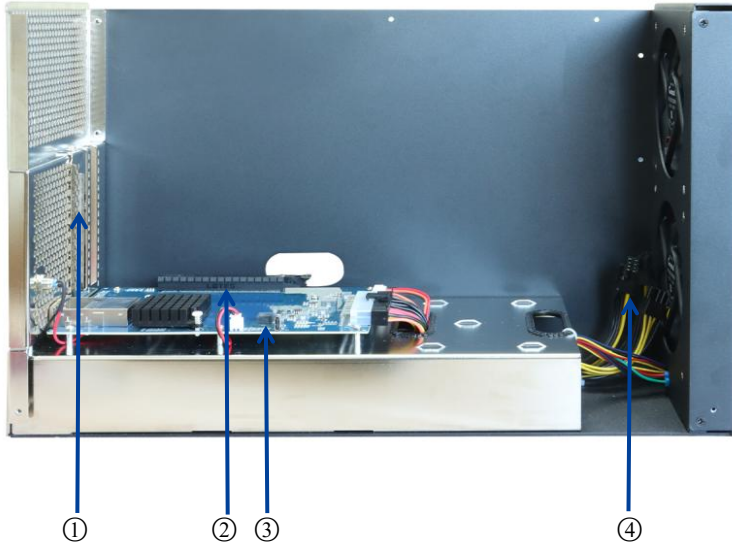

The following table describes the key components of the Chassis rear panel.

**Table 6: Key components of the Chassis rear panel**

Number	Type	Description						
①	PCIe slot cover	Used to protect PCIe slots from dust and other physical damage.						
②	PCIe slot	Used to connect the GPU (Graphics Processing Unit).						
③	Beeper	<p>The beeper will appear in the following 3 beeping statuses:</p> <p><b>Notes:</b></p> <p>1 means alarming, and 0 means not alarming.</p> <p>This setting takes effect temporarily, not permanently.</p> <table border="1"> <tbody> <tr> <td><b>1-0-1-0-1-0</b></td> <td>The Fan Speed is &lt; 100 RPM.</td> </tr> <tr> <td><b>1-0-0-1-0-0</b></td> <td>The beeper will chirp when any of the following conditions are triggered. <ul style="list-style-type: none"> <li>The Retimer chip temperature is &gt; 100°C.</li> <li>The LM75 temperature is &gt; 80°C.</li> </ul> </td> </tr> <tr> <td><b>1-1-1-1-1-1</b></td> <td>Both “1-0-1-0-1-0” and “1-0-0-1-0-0” above occur simultaneously.</td> </tr> </tbody> </table>	<b>1-0-1-0-1-0</b>	The Fan Speed is < 100 RPM.	<b>1-0-0-1-0-0</b>	The beeper will chirp when any of the following conditions are triggered. <ul style="list-style-type: none"> <li>The Retimer chip temperature is &gt; 100°C.</li> <li>The LM75 temperature is &gt; 80°C.</li> </ul>	<b>1-1-1-1-1-1</b>	Both “1-0-1-0-1-0” and “1-0-0-1-0-0” above occur simultaneously.
<b>1-0-1-0-1-0</b>	The Fan Speed is < 100 RPM.							
<b>1-0-0-1-0-0</b>	The beeper will chirp when any of the following conditions are triggered. <ul style="list-style-type: none"> <li>The Retimer chip temperature is &gt; 100°C.</li> <li>The LM75 temperature is &gt; 80°C.</li> </ul>							
<b>1-1-1-1-1-1</b>	Both “1-0-1-0-1-0” and “1-0-0-1-0-0” above occur simultaneously.							
④	2x4 connectors	Three 2x4pin power connectors. Powering the GPU.						

## 2.2. PCIe Host Interface

The RS8531AW's PCIe 5.0 host interface provides maximum transmission. Other PCIe host interface features include the following:

- 16-lane PCIe host interface
- Support of x16 link width
- 16-lane aggregate bandwidth of up to 32GB/s

## 2.3. Chassis Bus Interface

The RS8531AW has one PCIe slot. Other features include the following:

- Dedicated PCIe 4.0 x16 port
- Support one GPU
- Data transfer at 32GB/s

## 2.4. Basic Specifications

The following table describes the basic specifications of the RS8531AW.

**Table 7: Basic Specifications of RS8531AW**

Model	RS8531AW
Host Interface Card Dimensions	LP-MD2, Single Width
Chassis Dimensions	445mm * 286mm * 155mm (with feet pads)
Chassis Weight	5.59kg
Power Consumption	<ul style="list-style-type: none"> <li>● <b>Idle mode:</b> 4.46W</li> <li>● <b>Burst mode:</b> 31.32W</li> </ul> Notes: The Burst mode power consumption is measured with the ASUS TUF-RTX4080S-O16G-GAMING. Actual power consumption may differ based on system hardware and configuration.
Operating Voltage	100V ~ 240V AC In; 600W
Work Temperature	+5°C ~ +55°C
Storage Temperature	-20°C ~ +80°C
MTBF (Mean Time Before Failure)	920,585 Hours

## 3. Controller Card Connector

### 3.1. CDFP Connector Pin Designation

The controller card has one CDFP connector.

The following figure shows the connector pin designation.

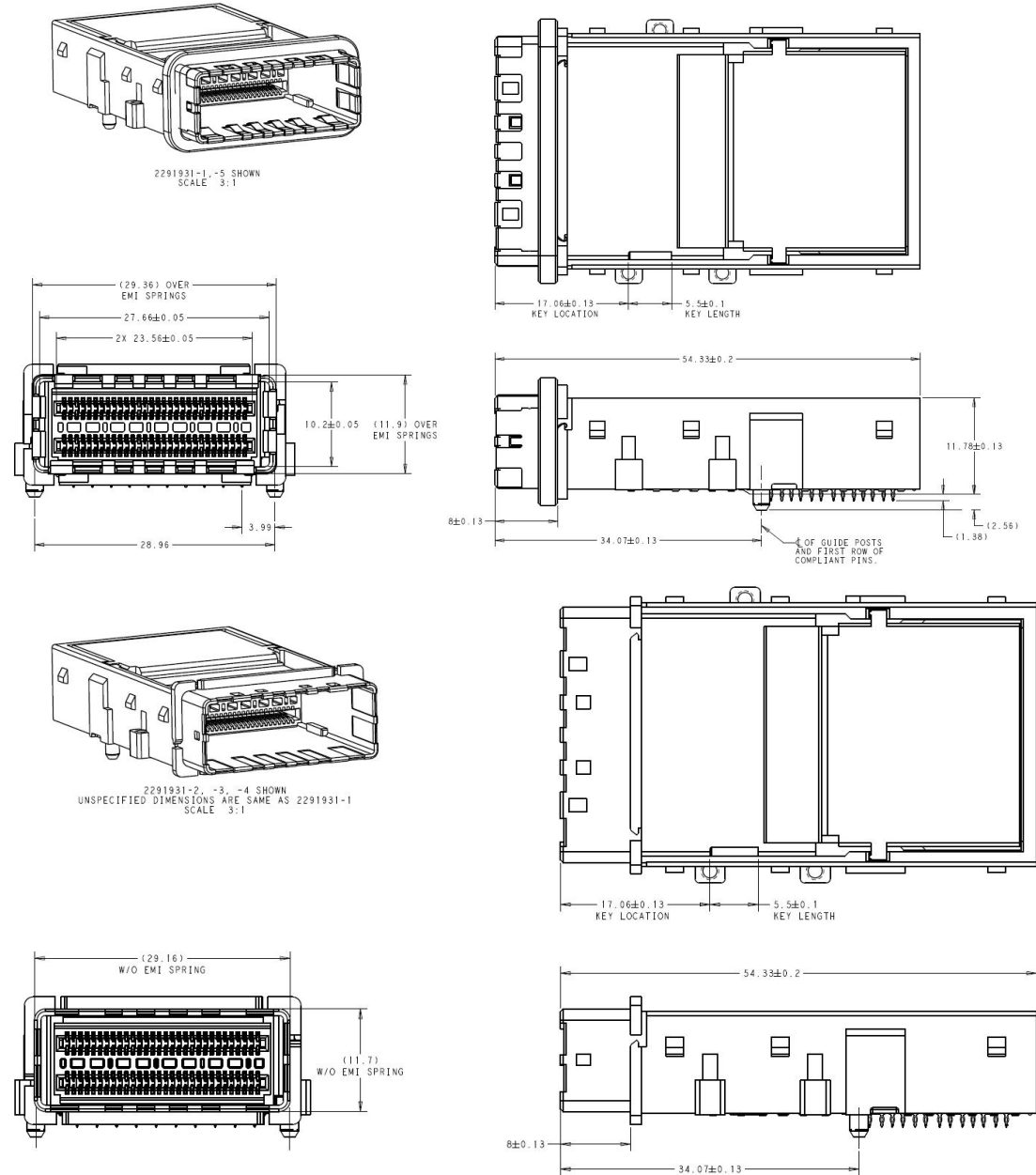

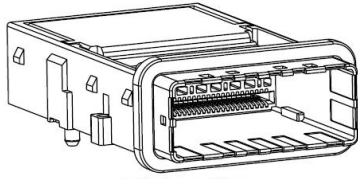

2291931-6/-7 SHOWN  
UNSPECIFIED DIMENSIONS ARE SAME AS 2291931-1  
SCALE 3:1

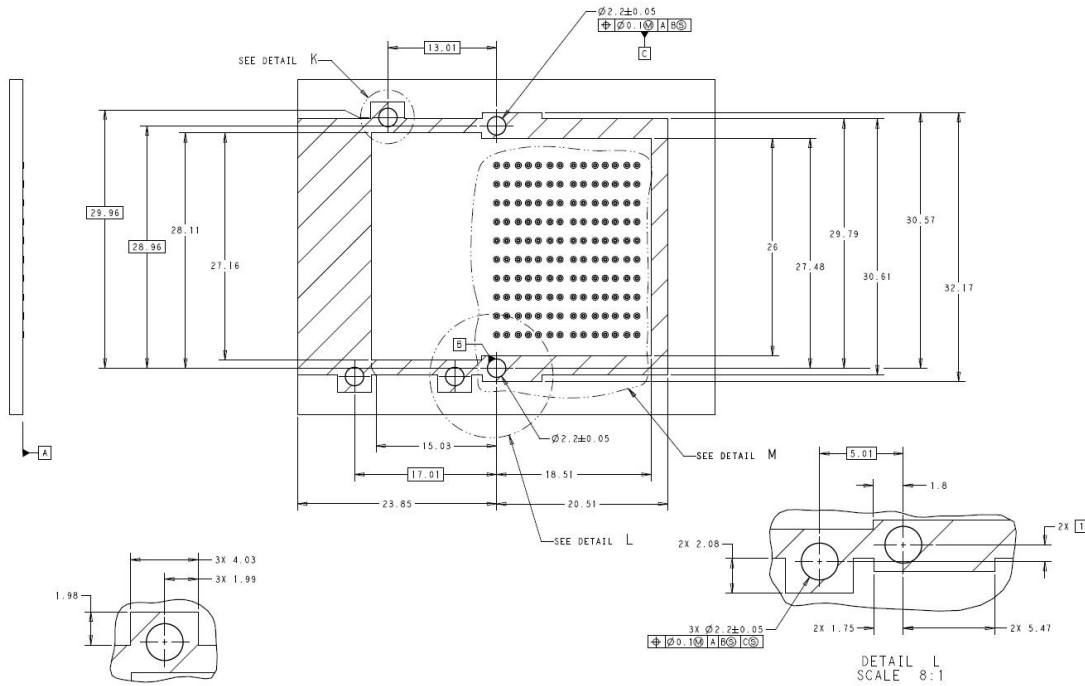
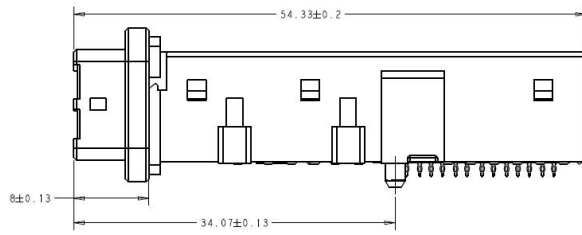
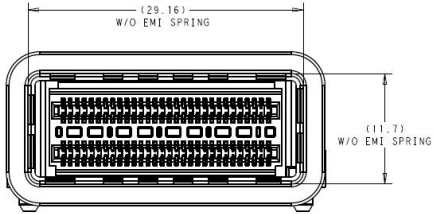
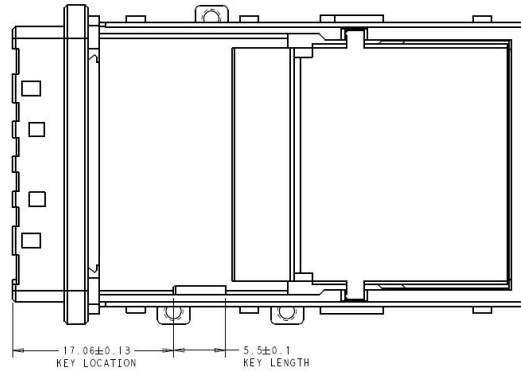

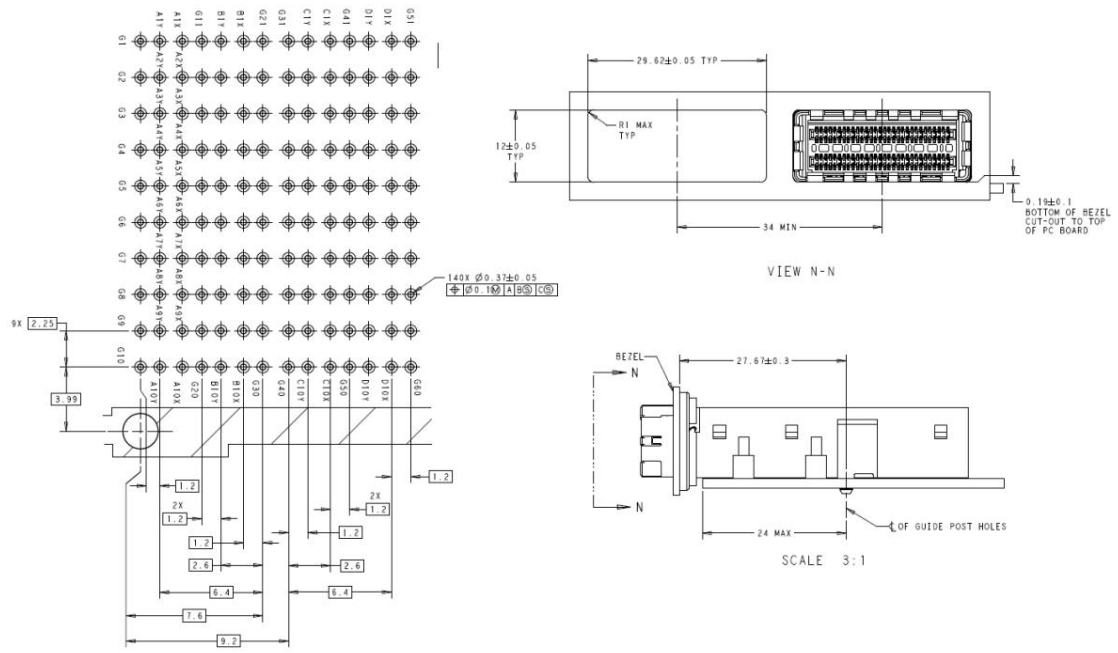

## 3.2. CDFP Connector Pinout

The following table defines the RS8531AW's controller card CDFP connector pinouts.

**Table 7: Connector Pinouts**

Pin	Name	Pin	Name
G1	GND	G11	GND
A1X	TX14P	B1X	TX15P
A1Y	TX14N	B1Y	TX15N
G2	GND	G12	GND
A2X	TX12P	B2X	TX13P
A2Y	TX12N	B2Y	TX13N
G3	GND	G13	GND
A3X	TX10P	B3X	TX11P
A3Y	TX10N	B3Y	TX11N
G4	GND	G14	GND
A4X	TX8P	B4X	TX9P
A4Y	TX8N	B4Y	TX9N
G5	GND	G15	GND
A5X	REF0_CLK+	B5X	CDFP_ID_0
A5Y	REF0_CLK-	B5Y	CDFP_ID_1
G6	GND	G16	GND
A6X	TX06P	B6X	TX7P
A6Y	TX06N	B6Y	TX7N
G7	GND	G17	GND
A7X	TX4P	B7X	TX5P
A7Y	TX4N	B7Y	TX5N
G8	GND	G18	GND
A8X	TX2P	B8X	TX3P
A8Y	TX2N	B8Y	TX3N



G9	GND	G19	GND
A9X	TX0P	B9X	TX1P
A9Y	TX0N	B9Y	TX1N
G10	GND	G20	GND
A10X	RESET1#	B10X	PRSNT1#
A10Y	GPIO0	B10Y	PRSNT2#
G31	GND	G41	GND
C1X	RX14P	D1X	RX15P
C1Y	RX14N	D1Y	RX15N
G32	GND	G42	GND
C2X	RX12P	D2X	RX13P
C2Y	RX12N	D2Y	RX13N
G33	GND	G43	GND
C3X	RX10P	D3X	RX11P
C3Y	RX10N	D3Y	RX11N
G34	GND	G44	GND
C4X	RX8P	D4X	RX9P
C4Y	RX8N	D4Y	RX9N
G35	GND	G45	GND
C5X	I2C0_CLK	D5X	I2C1_CLK
C5Y	I2C0_SDA	D5Y	I2C1_SDA
G36	GND	G46	GND
C6X	RX6P	D6X	RX7P
C6Y	RX6N	D6Y	RX7N
G37	GND	G47	GND
C7X	RX4P	D7X	RX5P
C7Y	RX4N	D7Y	RX5N
G38	GND	G48	GND
C8X	RX2P	D8X	RX3P

C8Y	RX2N	D8Y	RX3N
G39	GND	G49	GND
C9X	RX0P	D9X	RX1P
C9Y	RX0N	D9Y	RX1N
G40	GND	G50	GND
C10X	GPIO1	D10X	GPIO2
C10Y	RESET2#	D10Y	GPIO3
G21	GND	G51	GND
G22	GND	G52	GND
G23	GND	G53	GND
G24	GND	G54	GND
G25	GND	G55	GND
G26	GND	G56	GND
G27	GND	G57	GND
G28	GND	G58	GND
G29	GND	G59	GND
G30	GND	G60	GND

## 4. Cable Accessory

The RS8531AW provides a cable that enables the controller card to have a configuration of U.2/U.3 NVMe SSDs via CDFP connectors.

The following sections describe the cable pinout and connection diagrams for the supported cable accessory.

### 4.1. CDFP-CDFP-1M

CDFP Host to CDFP Device cable. Length 1M.

#### 4.1.1. Cable Diagram



#### 4.1.2. Cable Drawings and Pinouts

##### CDFP

The following figure shows the pinout for the HighPoint CDFP-CDFP-1M cable, one x8 CDFP to one x8 CDFP connection.

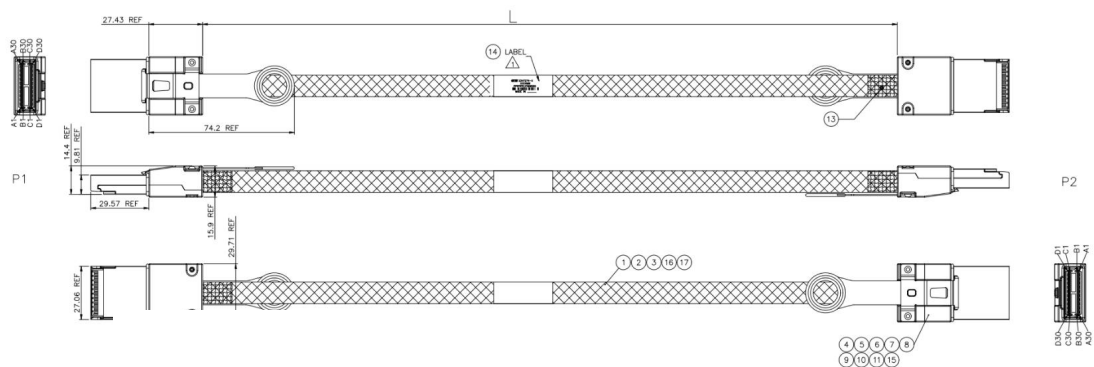

WIRE CHART

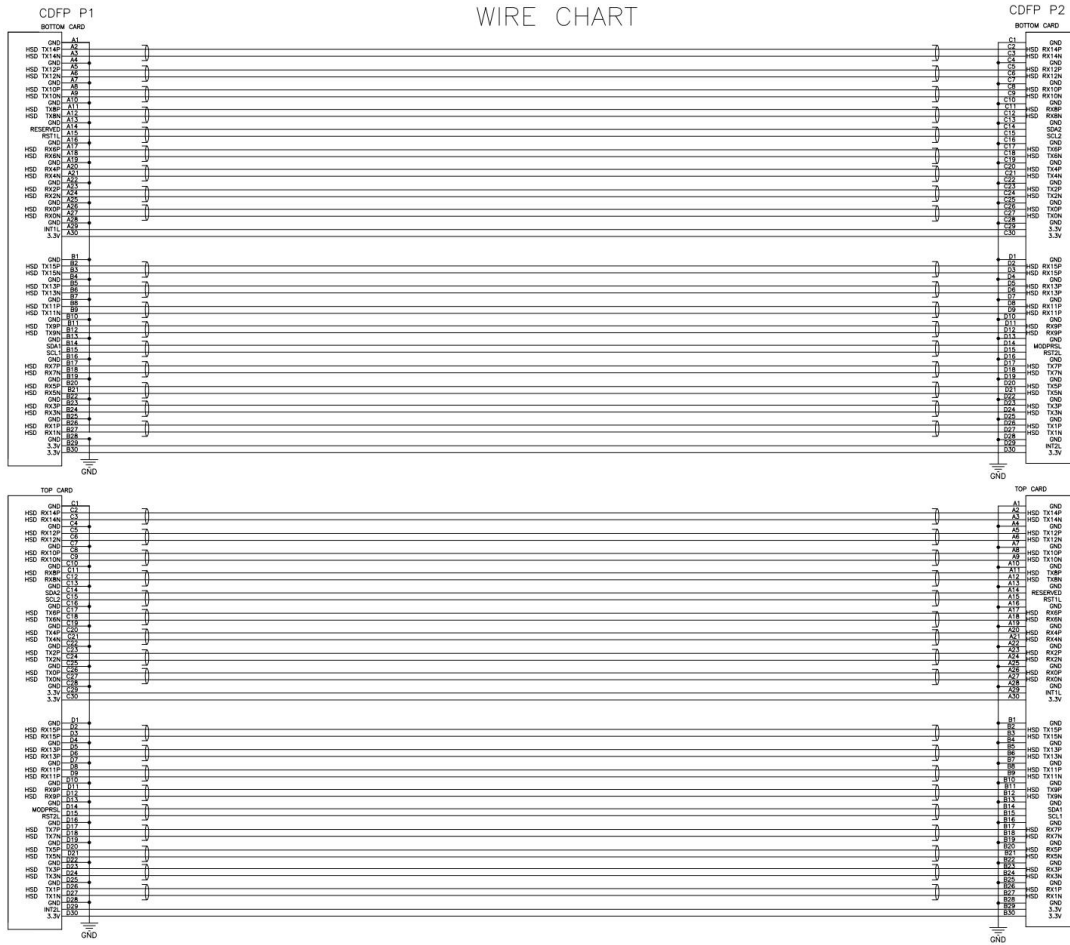

## 5. RS8531AW Installation Instructions

1. Use a wired ESD wrist strap that is properly grounded.
2. Unpack and remove the RS8531AW and check it for damage.  
If it appears damaged, please get in touch with HighPoint Technical Support.
3. Turn the thumbscrew counterclockwise and remove the four screws at the bottom of the left side and right side.



4. Gently Remove the RS8531AW cover.

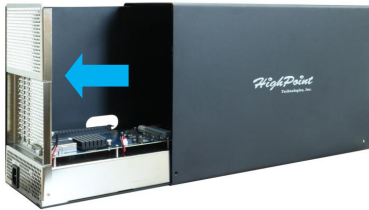

5. Remove the screw and PCIe slot cover.



Note: Remove the screw and PCIe slot cover according to the width of the accessed GPU (Maximum support for one triple-width GPU).

6. Remove the cable trunking by removing the four screws on the back of the Chassis.

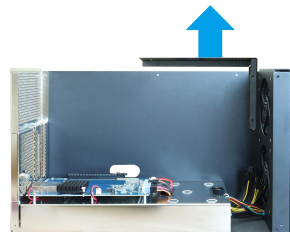

7. Hold the GPU by its edges, insert it connector-down into the slot, and secure the GPU bracket with screws.

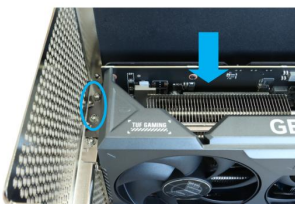

8. Install the cable trunking by reattaching the four screws on the back of the Chassis.

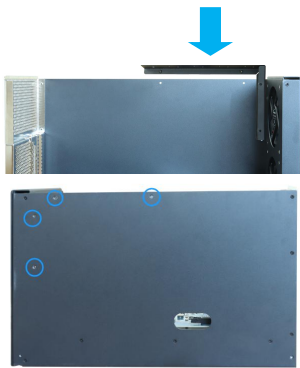

9. Connect the GPU power connector to the power connectors inside the Chassis.



Note: If the GPU power cable is not long enough, refer to the following steps to connect the GPU using the 2x4 connectors to the 2x4 connector Cables.

- 1) Connect the 2x4 connectors to the power connectors inside the Chassis.

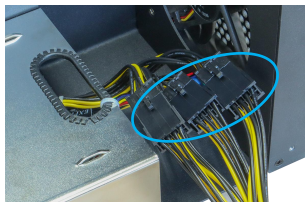

- 2) Place the 2x4 connectors to 2x4 connectors cables into the cable trunking and tie the cables with cable ties.

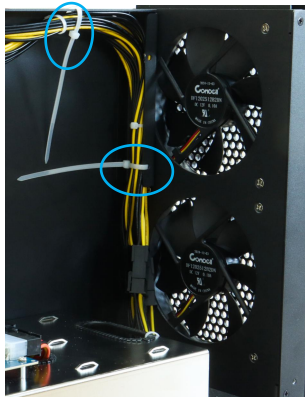

The recommended number of cable ties is between two and four, and the ties should be placed horizontally and vertically.

10. Close the RS8531AW Chassis, and screw back screws and thumbscrew that were removed in step3.



11. Connect the CDFP cable to the Host Interface Card's external port.

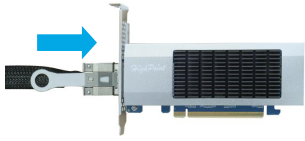

12. Connect the CDFP cable to the Chassis's CDFP port and the UL power cord to the Chassis for AC power connection.

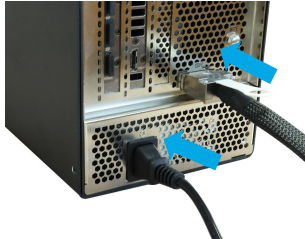

13. Insert the Host Interface Card into the motherboard's PCIe x16 slot.
14. Press the power button to turn on the power up the RS8531AW, then power up the motherboard.

## **6. Revision History**

### **Version 1.00, March 20, 2025**

Initial version.